

Plumbing Installations



Plumbing Requirements for a
Single-Family Dwelling

Neepawa & Area Planning District

Contents

General Information..... 3
Inspections 5
New Drain and Vent Installations 5
Potable Water Systems 17
Protection from Contamination by Cross Connections 18
Contact Us back cover

Note

This booklet provides a general overview of requirements for common plumbing installations. This booklet is not intended to cover all of the plumbing regulations. Complete plumbing requirements are covered in the Manitoba Plumbing Code (NPC 2010 with Manitoba Amendments).

If you have questions or concerns not covered in this booklet, please contact the Neepawa & Area Planning District. See back of booklet for contact information.

Every effort has been made to ensure the accuracy of the information contained in this booklet. However, in case of a discrepancy between this booklet and the Manitoba Plumbing Code, the Code will take precedence.

General Information

When is a plumbing permit required?

A plumbing permit must be obtained whenever:

- a) a plumbing system is constructed on new construction
- b) whenever a plumbing system is being extended or altered

When is a plumbing permit not required?

A plumbing permit is not required when:

- a) a stoppage in the drainage system is cleared
- b) a leak is repaired in a water distribution system
- c) a fixture is replaced without any change to the drainage system; or
- d) a replacement is made to existing faucets, or service water heaters

NOTE: A permit may be required from the utility for the service water heater.

Who may obtain a plumbing permit?

Plumbing permits can be issued to:

- a) to a plumbing contractor
- b) to the owner/ or authorized agent of a property

NOTE: A contractor may be required to obtain a Contractor's License from the local municipality.

What information is required to apply for a plumbing permit?

In all cases, sufficient vertical clearance shall be provided to allow accessible access for servicing and replacement of heating, plumbing and other equipment located under the home.

To obtain a plumbing permit, the homeowner/contractor may be required to present a plumbing diagram for the proposed installation with the following details. The diagram must:

- a) have a view from the side
- b) be drawn as single line
- c) show the drain and vent sizes
- d) show the location of each fixture

See Figure 1.

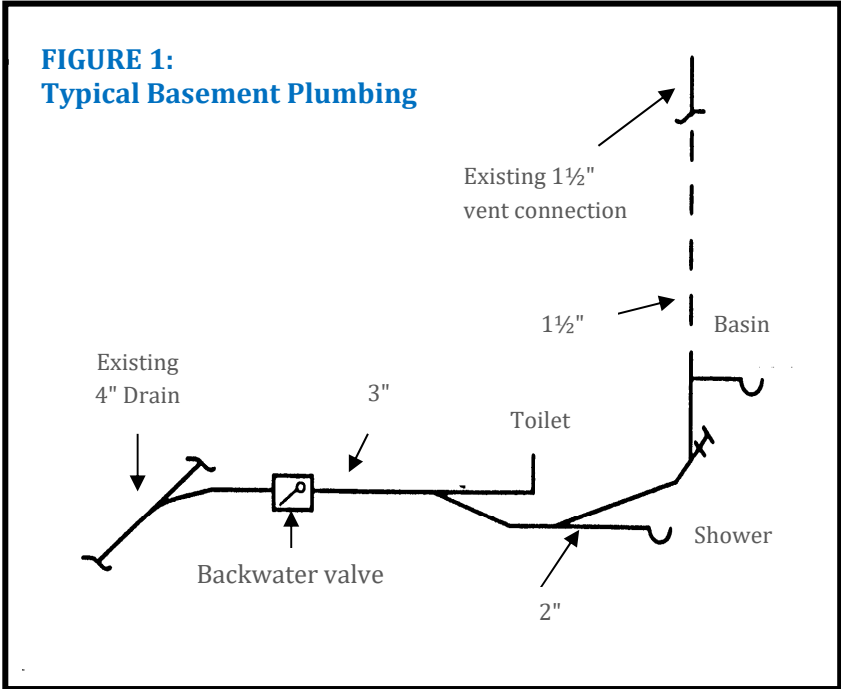

How much does a plumbing permit cost?

The plumbing permit fee schedule is as follows:

- a) Single family dwellings \$100.00
- b) Additional plumbing fixtures \$15.00 per fixture

NOTE: There is no fee for installing fixtures to a system that was already roughed-in.

Inspections

What must be ready for an inspection?

If a plumbing inspection is called for, the entire system is to be left uncovered. If the inspector is unable to get to the site the day of the request, alternate arrangements may have to be met (e.g. photos taken, test witnessed, etc.)

New Drain and Vent Installations

What is the minimum slope requirement for drains?

All drains must be installed to provide a minimum slope away from the fixture of at least 6mm ($\frac{1}{4}$ ") for every 300mm (1 ft.) of pipe length. The drains must be supported by a firm base/hanger to remain in that position.

See Figure 2.

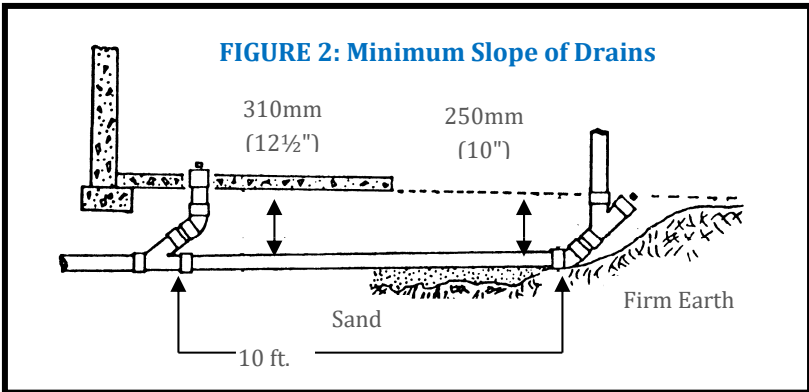

What is the total fall allowed from a fixture trap to the vent?

The total fall from the fixture trap to the vent shall not exceed the pipe diameter. See Figure 3.

FIGURE 3: Fall of Fixture Trap

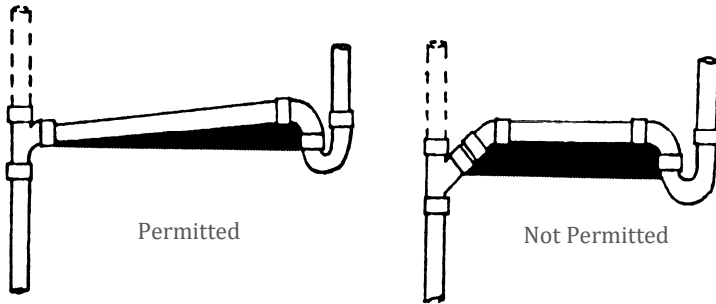

The "Shaded Area" that shows the fall must not be greater than the diameter of the pipe

Can drainage or water piping be installed in exterior walls?

Where piping may be exposed to freezing conditions, it must be protected. NO drainage or water system can be installed in any exterior wall of a building. Vent pipes are permitted in exterior walls.

Are expansion fittings required for piping systems?

Yes! The design and installation of every piping system must, where necessary, include means to accommodate expansion and contraction of the piping system caused by temperature change. Therefore, where plastic pipe is used, expansion joints must be installed at the base of every soil or waste stack. See Figure 4.

What is the maximum distance allowed between a vent pipe and a fixture trap or a water closet?

The maximum distance between a vent and a fixture trap depends on the diameter of the fixture drain. The total fall of the fixture drain shall not exceed the drain diameter. The distance between a vent pipe and a water closet must not exceed 3m (10 ft.) horizontal and 900mm (3 ft.) vertically. See Figure 4.

FIGURE 4: Lengths of Fixture Drains and Expansion Fitting

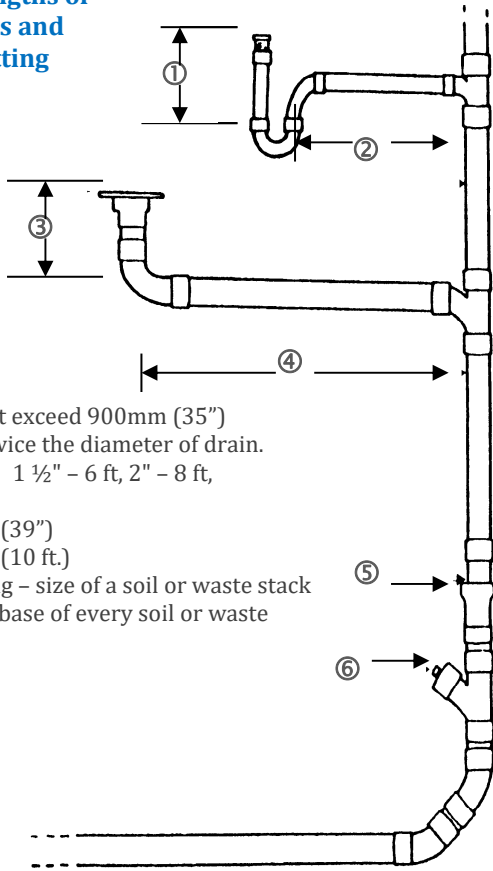

1. Length must not exceed 900mm (35")
2. Min. length is twice the diameter of drain.
Max. 1¼" - 5 ft, 1½" - 6 ft, 2" - 8 ft,
3" - 12 ft.
3. Max. length 1m (39")
4. Max. length 3m (10 ft.)
5. Expansion fitting - size of a soil or waste stack
6. Cleanout at the base of every soil or waste stack

What are the locations of the cleanout fittings in the drainage system?

Approved cleanout fittings must be installed at the following locations:

- a) as close as practicable to the point where the building drain leaves the building
- b) at the base of every soil or waste stack
- c) above the flood level rim of the kitchen sink if the vent runs nominally horizontal
- d) at every 90 degree change of direction in sink waste

See Figure 5.

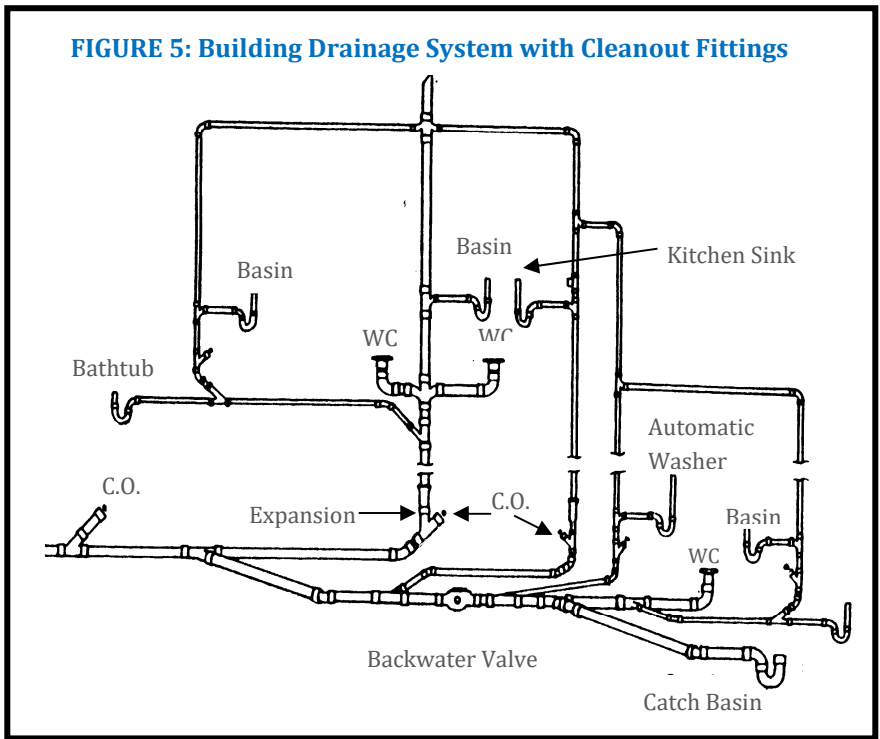

What are the requirements for the installation of “T” and “Y” fittings in the drainage system?

Tee fittings or 90 degree elbows must not be used in the horizontal portion of a drainage system. All changes of direction must be made with the use of Y's and 45 degree bends. Except that a 90 degree elbow or tee fittings may be used to change direction of horizontal drains when the direction of flow is down to the vertical. Tee fittings may be used to make the connections to vent pipes. See Figures 6 and 7. (For Exceptions, see Figure 8.)

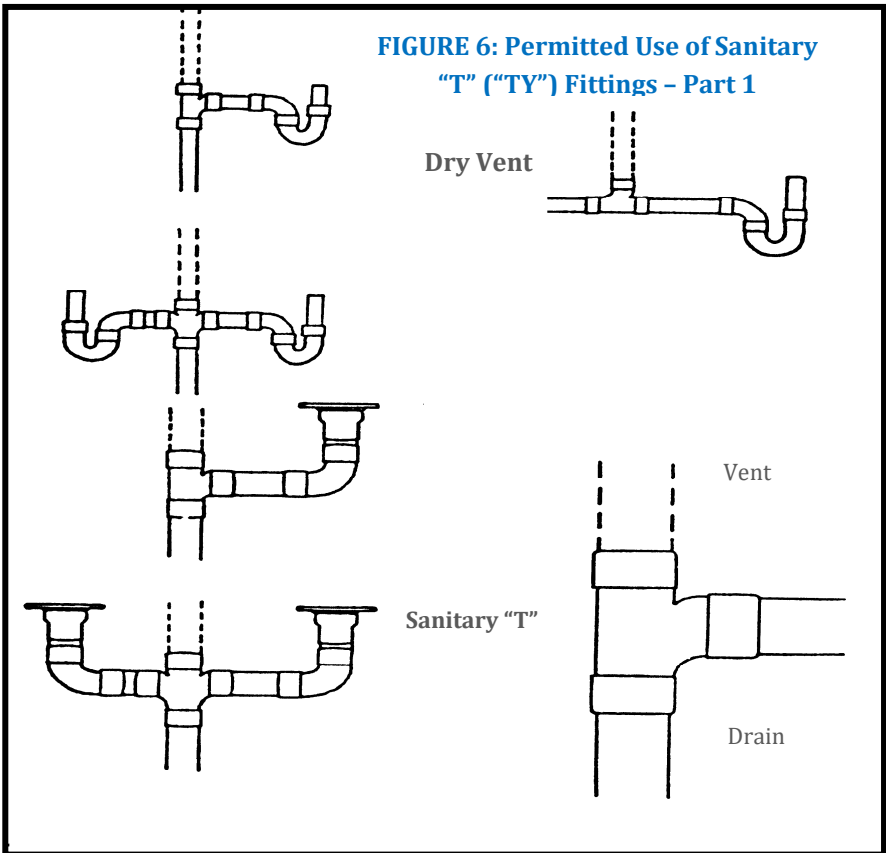

FIGURE 7: Permitted Use of Sanitary "T" (TY) Fittings

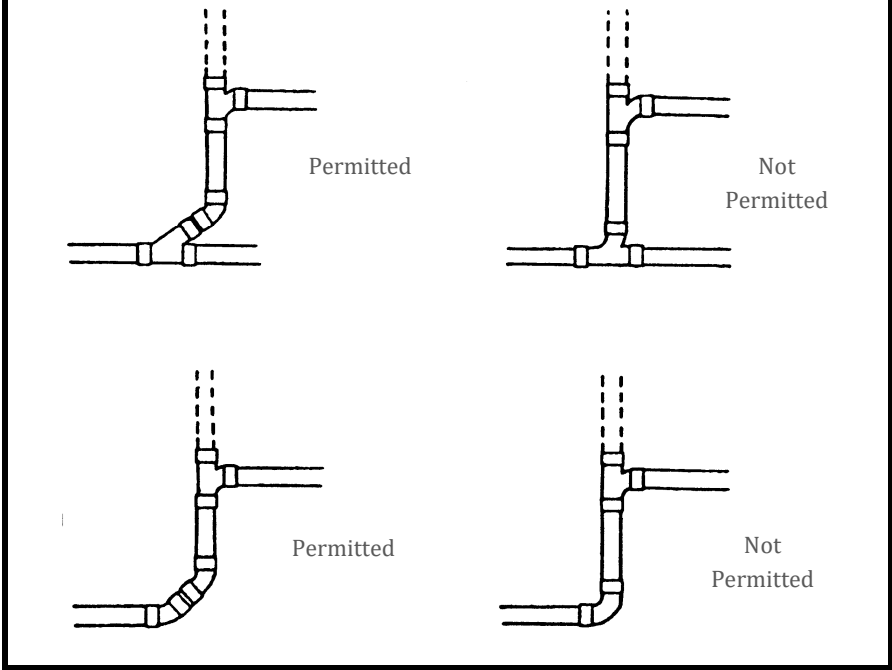
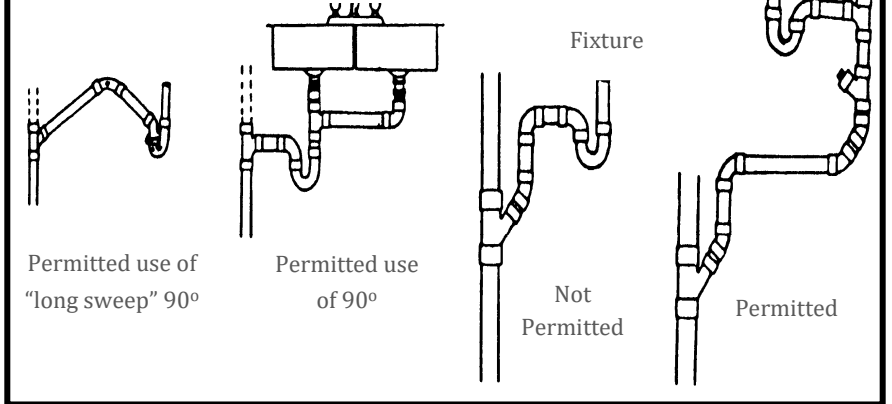

FIGURE 8: Permitted Use of Sanitary "T" (TY) Fittings - Exceptions



Is room ventilation for bathrooms required?

Yes! Ventilation of bathrooms or any room containing a water closet must be provided by either:

- a) a window with an openable area of at least 0.09m² (0.97sq.ft.)
- b) a mechanical exhaust system (fan) to the outdoors

NOTE: Natural ventilation such as an openable window is considered suitable for summer use and tends not to be used in the winter, thus resulting in unacceptable air quality.

What requirements must be met for the venting of multiple fixtures?

A soil or waste pipe extending as a stack or a continuous vent may serve as a single storey vent if:

- a) all fixtures served by the vent are on the same storey
- b) the number of vented water closets does not exceed two
- c) when two water closets are installed they are connected at the same level by an approved double fitting
- d) water closets are connected down stream of all fixtures, and
- e) the fixture drains are connected separately and directly into the soil or waste pipe

See Figures 9, 10 and 11.

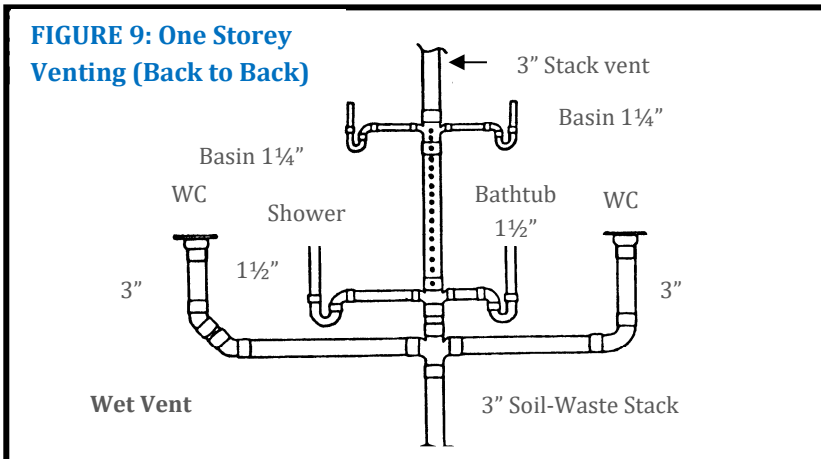
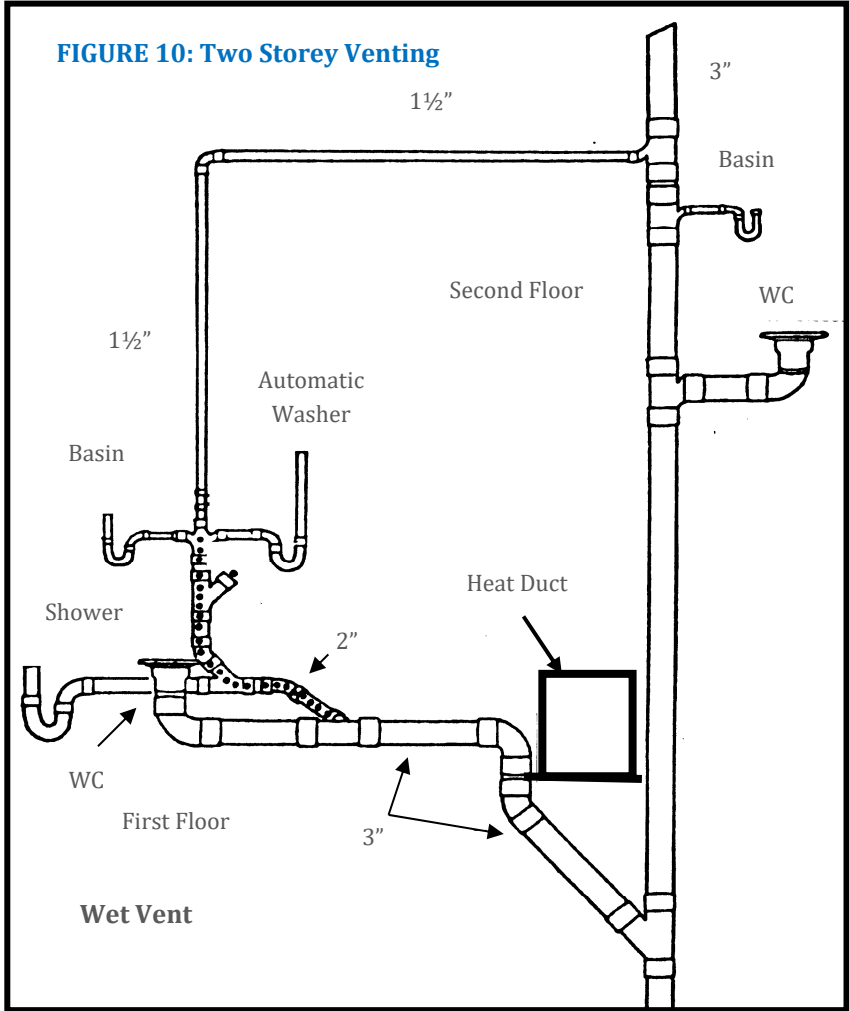

FIGURE 10: Two Storey Venting



When is a backwater valve required?

Backwater valves are required where:

- fixtures are installed below grade where they may be subject to surcharge from a public sewer
- all subsoil drainage shall be protected when connected to the building sewer, and
- backwater valves are not to be installed on the building drain unless it is designed to be in the normally open position

See Figures 10 & 11.

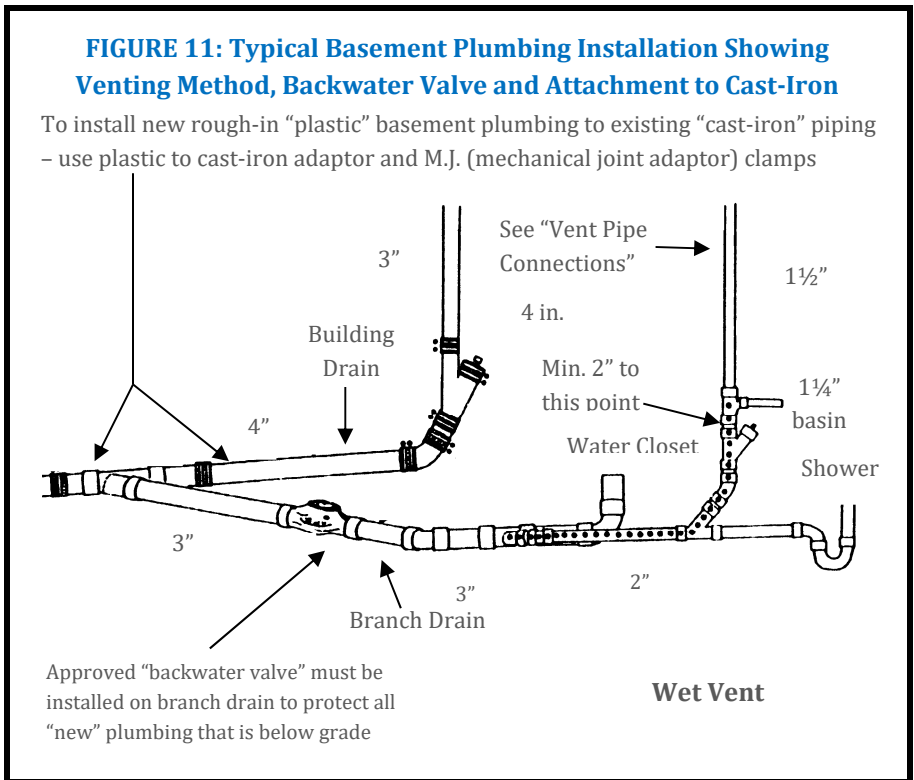

What is the maximum cumulative change in direction permitted between a fixture trap and a vent?

The cumulative change of direction between a fixture trap and a vent must not exceed 135 degrees.

See Figure 12.

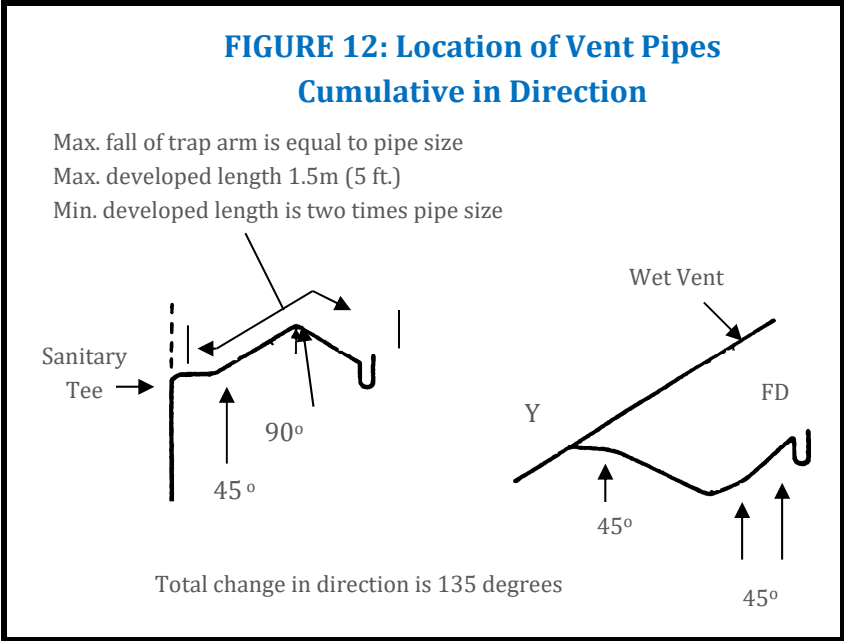

What are some requirements to be met when vent pipes are being connected and being run through the dwelling to the roof?

- a) Where a vent pipe passes through the roof, it must be protected from frost closure by increasing the pipe diameter to at least 3 inches before penetrating the roof.
- b) The vent piping in the attic to be insulated.
- c) Vent pipes must be installed without depressions in which moisture can collect.
- d) A vent pipe must extend vertically above the flood level rim of every fixture that it serves before being connected to another vent pipe.

See Figure 13.

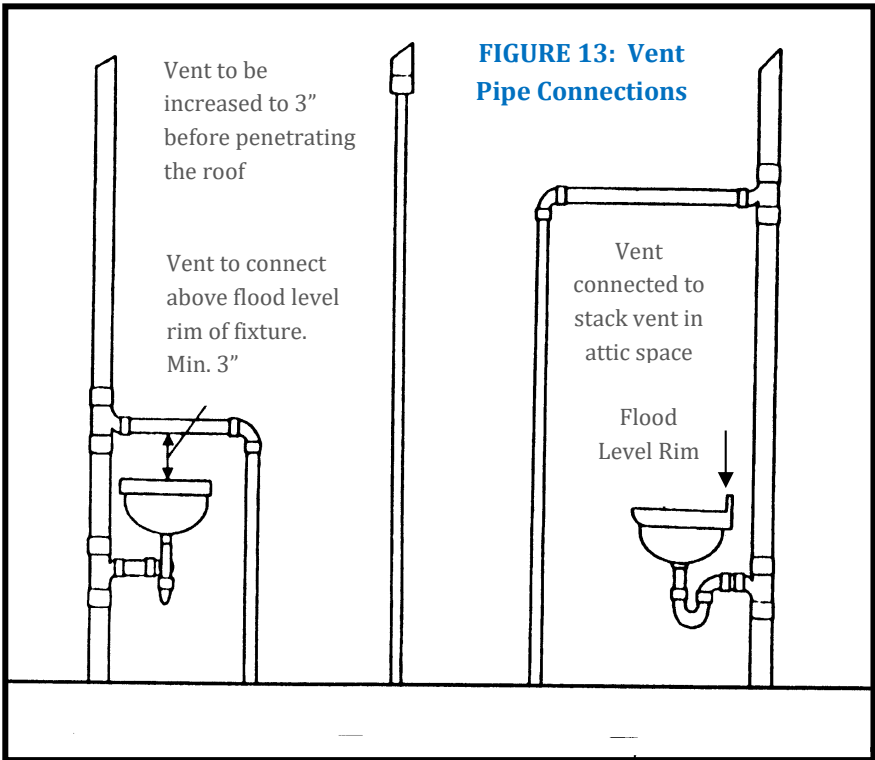
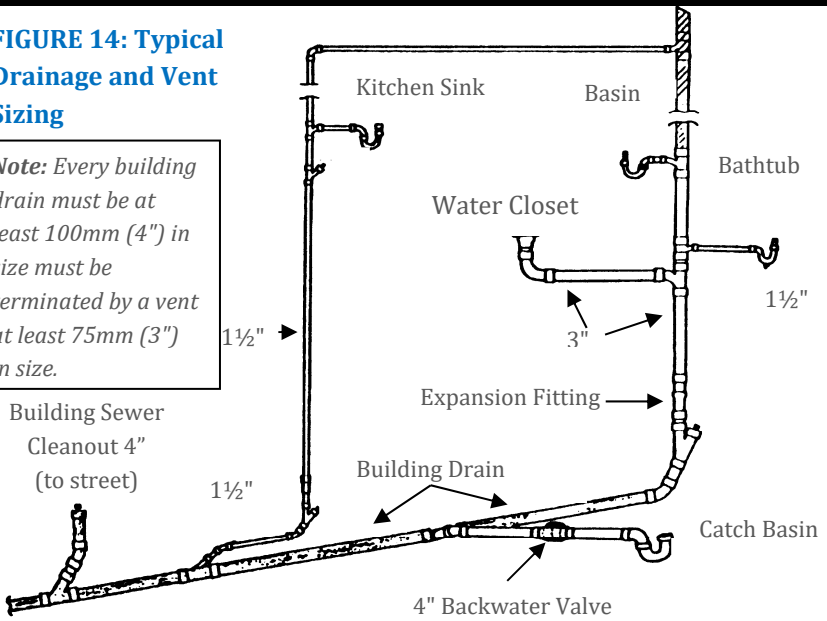

TABLE 1

Fixture	Min. Size of Fixture Outlet Pipe (Inches)
Bathtub (with or without shower)	1½"
Bidet	1¼"
Clothes Washer	1½"
Dishwasher (no load when connected to a garbage disposal units-residential type)	1½"
Laundry sinks	1½"
Lavatories	1¼"
Shower Drain	1½"
Sink – one and two compartments with garbage disposal unit	1½"
Water Closet	3"

FIGURE 14: Typical Drainage and Vent Sizing

Note: Every building drain must be at least 100mm (4") in size must be terminated by a vent at least 75mm (3") in size.



Potable Water Systems

What are the requirements that must be met for the installation of potable water systems?

All potable water systems must meet the following standards:

- a) Every water service pipe must be provided with a shut-off valve where the pipe enters the building
- b) A water distribution system must be installed so that it can be drained or blown out with air
- c) Every fixture supplied with Hot & Cold water controls must have the hot water on the left and the cold water on the right
- d) Every water closet must be provided with a shut-off valve
- e) Every pipe that passes through an exterior wall to supply water (i.e. lawn service) must be provided with a frost-proof hydrant or a stop-and-waste valve placed inside the building close to the outside wall or other approved location

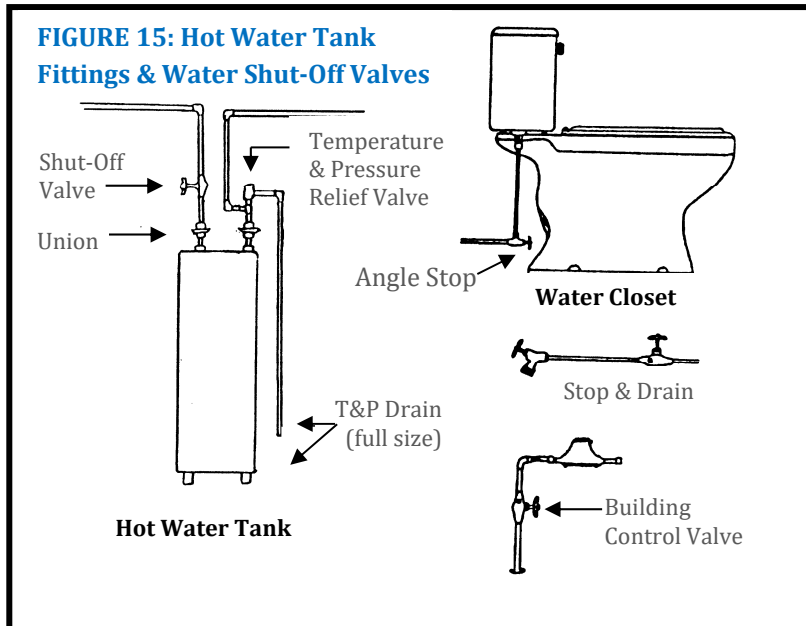

- f) Every Hot water tank must be provided with a shut-off valve and a pressure and temperature relief valve. The pressure and temperature relief valve must be designed to open when the water pressure in the tank exceeds the rated working pressure of the tank or when the water temperature exceeds 99°C (210°F). Every temperature and pressure relief valve must be provided with a drain and the drain must extend to within 300mm (12 in.) of the floor or to a safe location. See Figure 15.

Protection from Contamination by Cross Connections

How can your potable water system be protected from contamination by cross connection?

A hose bib vacuum breaker must be installed on every hose bib located outside a building or in a garage to isolate garden hose applications thus protecting the potable water supply from contamination.

Connections to potable water systems must be designed so that non-potable water, foreign matter, foreign chemicals or substances that may render the water non-potable cannot enter the system. A cross connection is a direct arrangement of piping, which allows the potable water supply to be connected to a line that contains a contamination. The purpose of a hose bib is to permit easy attachment of a hose for outside watering purposes. The ordinary garden hose is the most common offender as it can be easily connected to the potable water supply and used for a variety of potentially dangerous applications, some of which are listed below.

A garden hose can be:

- a) left submerged in a swimming pool
- b) placed in elevated locations watering shrubs
- c) have chemical sprayers attached, for spraying pesticides
- d) positioned lying on the ground that may be contaminated with fertilizer and garden chemicals

- e) attached to a laundry tub with the end of the hose submerged in a tub full of detergent, or
- f) connected to the supply lines of bottom fed tanks, and boilers, etc.

See Figure 16.

Back Siphonage and Backflow Prevention

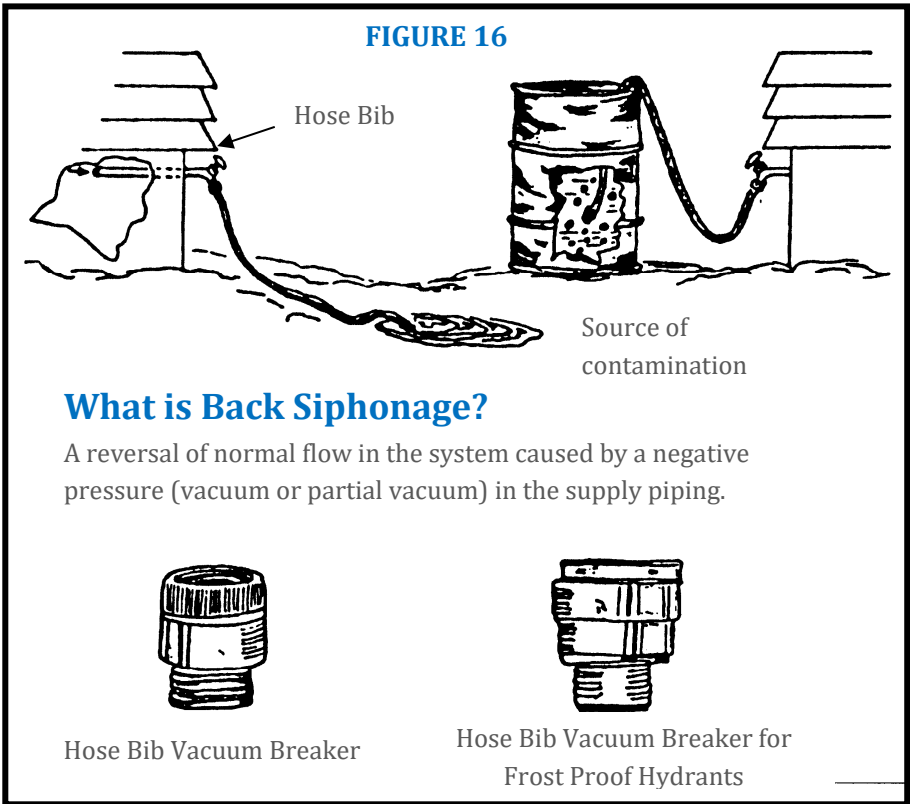

Contact Us

Neepawa & Area Planning District

Box 1720
275 Hamilton Street
Neepawa, MB R0J 1H0
Phone: 204.476-3277
Fax: 204-476-7624
Email: jeff@neepawaareaplanning.com
www.neepawaareaplanning.com

Or contact the member jurisdictions of Neepawa & Area Planning District:

Town of Neepawa

275 Hamilton St
Neepawa, MB R0J 1h0
Phone: 204-476-7600

Rural Municipality of Rosedale

282 Hamilton St
Neepawa, MB R0J 1H0
Phone: 204-476-5414

Municipality of Glenella-Lansdowne

50 Main St South
Glenella, Manitoba, R0J 0V0
Phone: 204-352-4281

Revised: March 2016